



# TECHNICAL SPECIFICATIONS JF200e

## DESCRIPTION

A 2-way full range system in a vented trapezoidal enclosure. Includes a 12-in woofer and a 2-in exit compression driver on a Wave Guide Plate™. Powering mode is switchable: passive (LF/HF crossover) or biamplified.

## APPLICATIONS

The JF200e offers concert-level output combined with natural, undistorted reproduction. Effective as a small nearfield main system or as a fill element in portable or permanent applications. Flytracks, mounting/suspension points, stand mount cup. Six year warranty.

Applications include:

- Band PA
- Ballroom Events
- Corporate Events
- Small Theaters
- Live Music Clubs
- Convention Centers

## DESCRIPTIVE DATA

Part Number	999060
Product Group	J
LF Subsystem & Loading	1x 12-in, Vented
HF Subsystem & Loading	1x 2-in Exit Compression Driver on Wave Guide Plate™
System Configuration	2-way, Full Range
Powering Configuration(s)	Switchable: Full Range (passive LF/HF crossover) or Biamplified
Controls (switches, knobs)	Powering Mode Switch
Recommended High-Pass Frequency (24 dB/Octave)	50Hz
Cabinet Type (shape)	Trapezoidal
Enclosure Materials	Baltic Birch Plywood
Finish	Black Catalyzed Polyurethane
Connectors	2x Neutrik NL4 Speakon
Suspension Hardware	(5) 3 Position Fly Tracks (2 each top and bottom, 1 back)/(10) 3/8"-16 Threaded Mounting/Suspension Points (3 each top and bottom, 2 each side)/(4) Threaded Mounting/Suspension Points for Omnimount Series 300 (back)/Recessed Cup for Standmount (bottom)
Grill	Vinyl Coated Perforated Steel
Options	179001 Flyclip with ring 179002 Flyclip with hook

## NOMINAL DATA

Frequency Response (Hz)	
±3 db	66Hz to 18kHz
-10 dB	55Hz



## Axial Sensitivity (dB SPL/1 Watt/1m)

Full Range	98
Biamped LF	98
Biamped HF	104

## Impedance (Ohms)

Full Range	8
Biamped LF	8
Biamped HF	8

## Power Handling, AES Standard (Watts)

Full Range	500
Biamped LF	500
Biamped HF	200

## Calculated Maximum Output (dB SPL, @ 1m)

Full Range Peak	131.0
Biamped LF Peak	131.0
Biamped HF Peak	133.0
Full Range Long Term	125.0
Biamped LF Long Term	125.0
Biamped HF Long Term	127.0

## Nominal Coverage Angle / -6 dB points (degrees)

Conical	90
---------	----

## Dimensions

	inches	millimeters
Height	22.43	570
Width (Front)	14.68	373
Width (Rear)	4.94	125
Depth	14.75	375
Trapezoid Angle	22.5 degrees per side	

## Weights

	pounds	kilograms
Net Weight	74	33.7
Shipping Weight	81	36.9





# TECHNICAL SPECIFICATIONS JF200e

## DIMENSIONAL DRAWING

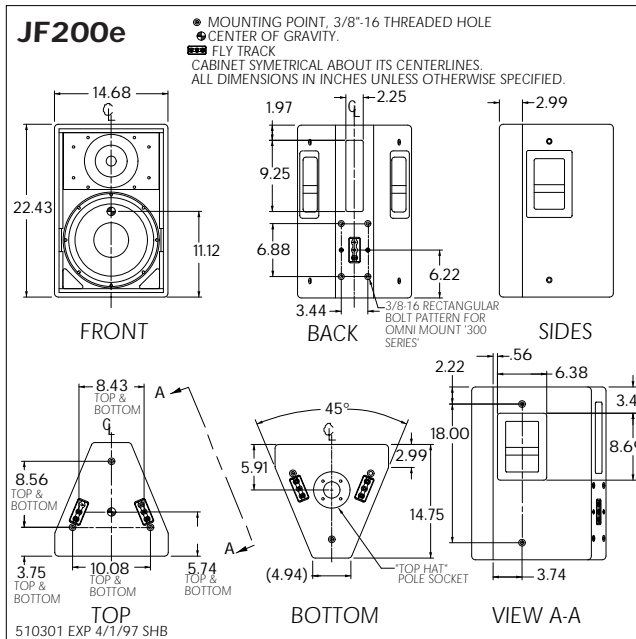

## SERVICE ITEMS

<b>LF: Complete Cone Driver</b>	EAW Part No. 804031
<b>HF: Complete Compression Driver/Tweeter</b>	EAW Part No. 803010
<b>Filter/Crossover Network: Complete Assembly</b>	EAW Part No. 225138

## ARCHITECTURAL SPECIFICATIONS

The two-way full range loudspeaker systems shall incorporate 12-in LF transducer and a 2-in exit compression driver HF transducer.

The LF driver shall be mounted in a vented enclosure tuned for optimum low frequency response. The HF driver shall be loaded on an axis-symmetrical wave guide plate with a nominal coverage pattern of 90° (conical). An internal passive filter network shall provide fourth order acoustical crossover and system equalization.

System frequency response shall vary no more than  $\pm 3$  dB from 66 Hz to 18 kHz measured on axis. In passive mode, the loudspeaker shall produce a Sound Pressure Level (SPL) of 98 dB SPL on axis at 1 meter with a power input of 1 Watt, and shall be capable of producing a peak output of 131 SPL on axis at 1 meter. It shall handle 500 Watts of amplifier power (AES Standard) and shall have a nominal impedance of 8 Ohms.

In biamped mode, the low frequency section shall meet all passive mode performance criteria. In addition, the high frequency section in biamped mode shall produce a Sound Pressure Level (SPL) of 104 dB SPL on axis at 1 meter with a power input of 1 Watt, and shall be capable of producing a peak output of 133 SPL on axis at 1 meter. The mid/high section biamped mode shall handle 200 Watts of amplifier power (AES Standard) and shall have a nominal impedance of 8 Ohms.

The loudspeaker enclosure shall be trapezoidal in shape. It shall be constructed of 15mm thickness void-free cross-grain-laminated Baltic birch plywood and shall employ extensive internal bracing. It shall be finished in black catalyzed polyurethane. Input connectors shall be dual Neutrik NL4 Speakon. The system shall include a switch allowing it to be operated in biamp or passive Powering Configuration(s). The following mounting/suspension hardware shall be provided: five 3-position flytracks (2 top, 2 bottom, 1 back); ten 3/8"-16 threaded mounting/suspension points (3 top, 3 bottom, 2 each side); four threaded points for an Omnimount Series 300 (back); a recessed cup to accept a standmount pole. The front of the loudspeaker shall be covered with a vinyl coated perforated steel grill backed with open cell foam to protect against dust.

The two-way full range loudspeaker shall be the EAW model JF200e.