



TECHNICAL SPECIFICATIONS SB1000z

FEATURES

- Virtual Array(tm) subwoofer system
- 2x 18-in woofer on slanted baffles, optimally vented
- Engineered to create subwoofer arrays
- P (install) or R (portable) versions available

DESCRIPTION

A portable subwoofer system with 2x 18-in transducers in a vented rectangular enclosure.

APPLICATIONS

The SB1000z high output Stadium Array Series subwoofer's slanted baffles maximize cone area and minimize frontal area for flexibility in creating large subwoofer arrays. Flytracks allow it to be flown with an array. Engineered to complement the KF850 family of full range main systems. MX Series processors extend LF response and safeguard against cone excursion damage. Six Year Warranty.

Applications include:

- Concert Tours
- Corporate Events
- Large Theaters
- Arenas
- Large HOW's
- Live Music Clubs

DESCRIPTIVE DATA

Components	2x 18-in, Vented	
Configuration	Dedicated Subwoofer	
Cabinet Type (shape)	Rectangular (1 slant corner for casters)	
Enclosure Materials	Baltic Birch Plywood	
Finish	Wear-resistant Textured Black Paint	
Connectors	1 Each Male and Female AP4 2x Neutrik NL4 Speakon	
Suspension Hardware	(4) 3-Position Flytracks (2 per side)	
Grill	Powder Coated Perforated Steel, Foam Backed	

Dimensions	Inches	Millimeters
	Height	21.19
Width	29.81	757
Depth (top)	42.81	1087
Depth (bottom)	34.63	880

Weights	Pounds	Kilograms
	Net Weight	188
Shipping Weight	193	87.8





TECHNICAL SPECIFICATIONS SB1000z

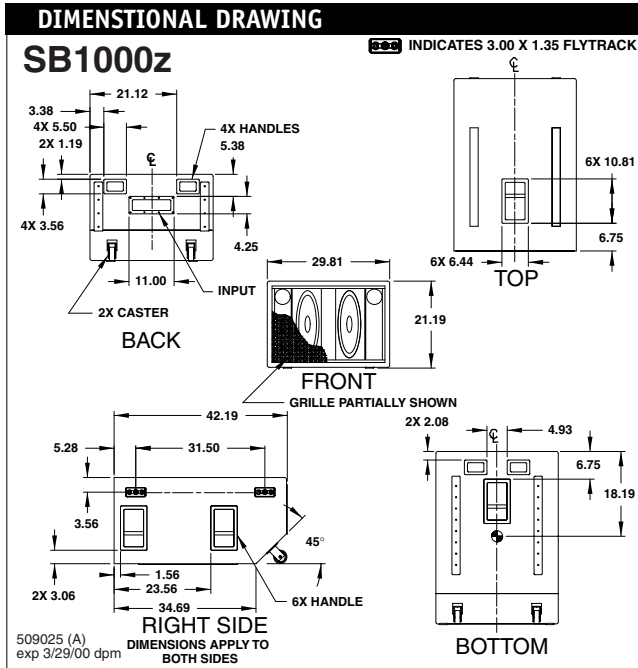

NOMINAL DATA

Frequency Response (1 Watt @ 1m)	
±3 dB	30Hz (42Hz w/out CCEP) to 100Hz
-10 dB	25Hz (27Hz w/out CCEP)
Axial Sensitivity (dB SPL, 1 Watt @ 1m)	
	99
Impedance (Ohm)	
	4 or 2 x 8
Power Handling (Watts)	
AES Standard	2000
Calculated Maximum Output (dB SPL @ 1m)	
Peak	138.0
Long Term	132.0
Recommended High-Pass Frequency	
24 dB/Octave	20Hz

ARCHITECTURAL SPECIFICATIONS

The sub bass loudspeaker systems shall incorporate 2x 18-in LF transducer mounted in a vented enclosure tuned for optimum low frequency response. The drivers shall be mounted in angled internal baffles.

System frequency response shall vary no more than ±3 dB from 30 Hz to 100 Hz measured on axis with appropriate signal processing. The loudspeaker shall produce a Sound Pressure Level (SPL) of 99 dB SPL on axis at 1 meter with a power input of 1 Watt, and shall be capable of producing a peak output of 138 SPL on axis at 1 meter. The loudspeaker shall handle 2000 Watts of amplifier power (AES Standard) and shall have a nominal impedance of 4 (2x 8) Ohms.

The loudspeaker enclosure shall be rectangular in shape. It shall be constructed of 15mm thickness void-free cross-grain-laminated Baltic birch plywood and shall employ extensive internal bracing. It shall be finished in wear-resistant textured black paint. Input connectors shall be one each male and female AP4 and dual Neutrik NL4 Speakon. 4x 3-position flytracks (2 per side) shall be provided. The front of the loudspeaker shall be covered with a powder coated perforated steel grill backed with open cell foam to protect against dust.

The sub bass loudspeaker shall be the EAW model SB1000z.